

Loader Vacuum Series

The Loader Vacuum Series let you clean up your dry spills with ease using a super-efficient, triple-filter system and strong, super-quiet regenerative type vacuum producer. The Loader systems have several options available in storage hopper size, blower horsepower, and filtration, so you'll get exactly the high performance vacuum solution you need. No matter the application!

Standard Features:

- Supports 2 to 7 operators using 1.5 in. ID hose, 3 operators using 2 in. ID hose, or other combinations
- Integrated storage hopper, .75 cubic yd to 2 cubic yd
- Power options include (60 Hz) 208v, 230v, 460v, 575v, and (50 Hz) 380v
- Primary filter efficiency of 99.99% @ 0.4 micron
- Inline safety filter for protection of the pump in case of filter primary failure, easily upgrades to HEPA
- Super – quiet, continuous duty regenerative vacuum producer available in 15 Hp to 75 Hp
- Effective, easy – to – reach external filter bag – shaker
- Easy – to – read filter condition differential pressure gauge
- Heavy duty, compact, all steel frame 53.5" (1358.9 mm) W x 76.25" (1936.75 mm) L x 103.56" (2630.42 mm) H, Weight – 2300 lbs (1043.3 KG)
- Built-in fork lift channels on the frame and storage hopper
- Configurable for portable or central vacuum system

Options:

- HEPA filtration
- Pulse jet filter cleaning
- Positive displacement vacuum pump
- Hot galvanized hopper lift, ideal for corrosive or outdoor environments

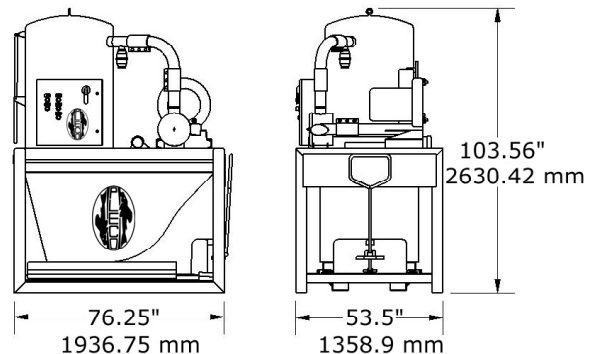

*Design subject to change without notice, due to continued research and improvements

AIR DYNAMICS INDUSTRIAL SYSTEMS CORPORATION

300 North Queen Street, York, PA 17403 USA

TEL: 717-854-4050

Email: sales@airdynamics.net

FAX: 717-854-4020

- Pollution Control Systems
- Industrial Vacuum Systems
- Oil Mist Collection Systems

Check out our full feature website at www.airdynamics.net