



Industrial Loader Vacuum System Rental

The Loader Vacuum Series let you clean up your dry spills with ease using a super-efficient, triple-filter system and strong, super-quiet regenerative type vacuum producer.

Industrial Loader Vacuum System Rental Features:

- Supports 2 to 7 operators using 1.5 in. ID hose, 3 operators using 2 in. ID hose, or other combinations
- Integrated storage hopper, 1 cubic yard
- Power requirements, 460/3/60
- Primary filter efficiency of 99.99% @ 0.4 micron
- Inline safety filter for protection of the pump in case of filter primary failure, easily upgrades to HEPA
- 25 Hp, super – quiet, continuous duty regenerative vacuum producer
- Effective, easy – to – reach external filter bag – shaker
- Hot galvanized hopper lift, ideal for corrosive or outdoor environments
- Heavy duty, compact, all steel frame 53.5" (1358.9 mm) W x 76.25" (1936.75 mm) L x 103.56" (2630.42 mm) H, Weight – 2300 lbs (1043.3 KG)
- Configurable for portable or central vacuum system
- Easy – to – read filter condition, differential pressure gauge

Options:

- HEPA filtration
- Pulse jet filter cleaning
- Positive displacement vacuum pump

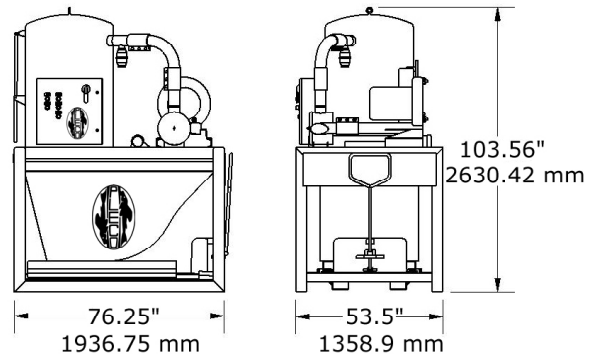

*Design subject to change without notice, due to continued research and improvements

AIR DYNAMICS INDUSTRIAL SYSTEMS CORPORATION

300 North Queen Street, York, PA 17403 USA

TEL: 717-854-4050

Email: sales@airdynamics.net

<http://www.airdynamics.net>

FAX: 717-854-4020

- Pollution Control Systems • Industrial Vacuum Systems • Simulated Environments
- Process Cooling • Advanced Coating Systems • Explosion Protection